



Proposed District Plan submission form



Clause 6 of the First Schedule, Resource Management Act 199.

Feel free to add more pages to your submission to provide a fuller response.

To: Central Hawke's Bay District Council			
1. Submitter details			
Full Name	Last	First	
Company/Organisation (if applicable)	Vodafone New Zealand Limited		
Contact Person (if different)	Tom Anderson, Incite		
Email Address	tom@incite.co.nz and colin.clune@vodafone.com		
Address	PO Box 2058, Wellington	Postcode 6140	
Phone	Mobile 027 231 0246	Home	Work 04 801 6862
2. This is a submission on the Proposed District Plan for Central Hawke's Bay			
3. <input type="checkbox"/> <input checked="" type="checkbox"/> I could not gain an advantage in trade competition through this submission			
If you could gain an advantage in trade competition through this submission please complete point 4 below:			
4. <input type="checkbox"/> I am <input type="checkbox"/> I am not – directly affected by an effect of the subject matter of the submission that:			
(a) adversely affects the environment; and (b) does not relate to trade competition or the effects of trade competition. <i>(Please tick relevant box if applicable)</i>			
<i>Note: If you are a person who could gain an advantage in trade competition through the submission, your right to make a submission may be limited by clause 6(4) of Part 1 of Schedule 1 of the Resource Management Act 1991.</i>			
5. <input type="checkbox"/> <input checked="" type="checkbox"/> I wish to be heard in support of my submission in person <i>(Please tick relevant box)</i>			
6. <input type="checkbox"/> <input checked="" type="checkbox"/> I will consider presenting a joint case with other submitters, who make a similar submission, at a hearing. <i>(Please tick relevant box)</i>			
7. Do you wish to present your submission via Zoom? <input checked="" type="checkbox"/> <input type="checkbox"/> There may be submission points which are presented via Zoom			
8. Please complete section below <i>(insert additional boxes per provision you are submitting on):</i>			
The specific provision of the plan that my submission relates to:			
Please see the attached documentation			
Do you: <input type="checkbox"/> Support <input type="checkbox"/> Oppose <input type="checkbox"/> Amend <i>(Please tick relevant box)</i>			
What decision are you seeking from Council?			
Reasons:			
Please note: All submissions will be treated as public documents and will be made available on Council's website. However, you may request that your contact details (but not your name) be withheld. If you want your contact details withheld, please let us know by ticking this box. <input type="checkbox"/> I do not want my contact details to be withheld			



Vodafone New Zealand Limited (Vodafone) welcomes the opportunity to make a submission on the Proposed Central Hawkes Bay District Plan (herein referred to as the PDP). There are a number of proposed provisions that Vodafone supports, and we wish to note that the comments the telecommunications companies have provided through the Draft District Plan process have generally been accepted. There are however a number of matters that in the view of Vodafone require amendment prior to the PDP being made operative.

Vodafone submissions on the PDP are set out in the attached table. In relation to the matters raised Vodafone seeks further, consequential or alternative relief as may be necessary, desirable, or appropriate to give effect to the decision sought.

The telecommunication companies, alongside a number of other national and regional network utility providers, have been involved in a working group which has been developing a set of 'best practice' District Plan provisions for Network Utilities. Work on the best practice provisions has temporarily stopped after discussion with Ministry for the Environment (MfE) given the uncertainty as to how they could fit into the proposed Natural and Built Environment Act regime. However the best practice provisions continue to be used to inform conversations with Councils developing District Plans. Helpfully, those conversations are also providing important insight and information into the refinement of the provisions.

The best practice provisions development group is industry led and involves a joint working group of representatives from telecommunications, electricity, water, transport, gas, MfE, Local Government NZ, and iwi interests, with the working group being assisted by an independent planning consultant.

It is the strong view of Vodafone and Incite as their consultant planners, that network utility provisions in District Plans should be consistent across the country. In regard to building and maintaining critical utility networks, there is little variation across New Zealand. National telecommunication network operators depend on reasonable consistency of provisions to enable New Zealanders to access telecommunications and the benefits that brings.

Historically, and to a degree currently, national network utility operators, including the telecommunication companies, face variation in regional and district planning regimes across New Zealand. This effects the ability to efficiently rollout new technology, even with planning tools such as the National Environmental Standards for Telecommunication Facilities 2016 (NESTF). Generally, telecommunications infrastructure contains the same features and is of the similar size across the country, however bespoke rules generate increase costs, delays and uncertainty for the industry that is constantly upgrading or rolling out new technology (such as the rollout of 5G mobile telecommunications).

The purpose of the best practice provisions is essentially to achieve national consistency for infrastructure/network utilities in resource management plans and policy statements structure and format, reducing complexity and improving the clarity and user friendliness of plans. Its development came about from several submissions to the Resource Legislation Amendment Bill 2016, suggesting network utilities was potential content for the National Planning Standards. Of the range of suggestions put forward, topics relating to infrastructure and network utilities are commonly raised. Submissions included the following comments:

- It is expensive to submit on multiple plans on essentially the same thing;
- Consistency in resource management plans and policy statements structure and format would be welcomed, reducing complexity and improving the clarity and user friendliness of plans;
- Network utility design does not vary significantly across New Zealand however the plan rules and standards vary from Plan to Plan;
- Providing consistency in definitions and terms would be beneficial; and
- Reverse sensitivity should be dealt with on a consistent basis.

The telecommunication companies have received legal advice to review and provide comments on the policy framework for network utilities in the best practice provisions. The advice received was that the best practice provisions provides a comprehensive and beneficial framework for the protection and enablement of network utilities. The structure and terminology used is appropriate for a National Planning Standard prepared under the RMA. They identified that a key challenge with the best practice provisions is that the policy framework is complex and nuanced, but that this is necessary in the current planning environment which effectively requires that level of complexity to ensure that the priorities within the planning framework are clear.

Consequently, the best practice provisions as drafted provide a cohesive framework and therefore needs to be applies as a whole, rather than having aspects of it being “cherry picked” by local authorities to suit their needs. Removing aspects of the framework removed or changed runs a significant risk of the best practice provisions losing their effectiveness, as well as creating an inconsistent planning framework for infrastructure throughout the country (which it sought to avoid).

Consequently, our submission table, attached below, essentially seeks relief where appropriate that the equivalent best practice provision replaces the PDP provision. It also provides details of other provisions within the PDP where we wish to support, amend or delete.

A copy of the best practice provisions are provided in Appendix A to this submission.

Vodafone New Zealand Limited

The specific submissions and the decisions sought for the Central Hawke's Bay Proposed District Plan are as follows:

Section/Sub-section/Provision	Support/Support in Part/Oppose	Submission	Relief sought
Part 1: Introduction and General Provisions			
How the Plan Works			
<i>Statutory Context</i>	Support	Having a statement detailing how National Environmental Standards and National Planning Standards relate to the District Plan is essential for user clarity	Retain the <i>Statutory Context</i> section
<i>General Approach</i>	Support	Stating the purpose of the Strategic Direction is crucial to understanding how the Strategic Objectives are to be implemented. Further, detailing Network Utilities as an <i>overriding district-wide chapter</i> where the provisions take precedence over the zone provisions (unless specified) provides clarity.	Retain the <i>General Approach</i> Section
Definitions			
<i>Aerial</i>	Oppose	The definition of <i>Aerial</i> is unnecessary, as it is the same as Antenna. Preference would be to include one definition, being that of Antenna (as it is the NESTF definition). Essentially at the moment the PDP has two terms (<i>Aerial</i> and <i>Antenna</i>) that cover the same matter. The term <i>Aerial</i> is only used twice in the PDP, and it is suggested	Delete the definition of <i>Aerial</i> , and make consequential changes in the PDP to change the term <i>Aerial</i> to <i>Antenna</i>

Section/Sub-section/Provision	Support/Support in Part/Oppose	Submission	Relief sought
		that on those two instances, the term <i>Aerial</i> is replaced with <i>Antenna</i> .	
<i>Antenna</i>	Support	As above, the definition of <i>Antenna</i> is supported as it is the NESTF definition.	Retain the definition of <i>Antenna</i>
<i>Cabinet</i>	Support	The definition of <i>Cabinet</i> is supported as it is the NESTF definition.	Retain the definition of <i>Cabinet</i>
<i>Functional Need</i>	Support	The definition of <i>Functional Need</i> is supported as it is the National Planning Standards definition.	Retain the definition of <i>Functional Need</i>
<i>Height</i>	Support	The definition of <i>Height</i> is supported as it is the National Planning Standards definition.	Retain the definition of <i>Height</i>
<i>Line</i>	Support	The definition of <i>Line</i> is supported as it is the Telecommunications Act 2001 definition.	Retain the definition of <i>Line</i>
<i>Maintenance</i>	Support	In relation to network utilities, the definition is clear as to what is considered to be within the ambit of maintenance	Retain the definition of <i>Maintenance</i>
<i>Mast</i>	Support	The term <i>Mast</i> is used within the Plan in relation to amateur radio configurations and renewable energy, but not telecommunications, which is appropriate, as discussed under the definition of <i>Pole</i> , below.	Retain the definition of <i>Mast</i>
<i>Nationally Significant Infrastructure</i>	Support in Part	A definition of the term Nationally Significant Infrastructure is appropriate. The matters that are listed in the definition all provide	Amend the definition of <i>Nationally Significant Infrastructure</i> as follows: <i>means:</i> <i>a. State Highways;</i>

Section/Sub-section/Provision	Support/Support in Part/Oppose	Submission	Relief sought
		<p>communities with the ability to connect or be serviced by a utility. Telecommunications allows people to connect at a local, regional, national and international level. The national significance of telecommunications is recognised through the presence of the NESTF. Telecommunications is also recognised in the Hawkes Bay Regional Resource Management Plan (which includes the Regional Policy Statement) as <i>Strategic Infrastructure</i>. Including telecommunications in the <i>Nationally Significant Infrastructure</i> is appropriate.</p>	<p><i>b. the National Grid electricity transmission network;</i> <i>c. national renewable electricity generation facilities that connect with the National Grid;</i> <i>d. major gas or oil pipeline services (such as the gas transmission pipeline from Taranaki);</i> <i>e. any railway (as defined in the Railways Act 2005).</i> <i>f. <u>Telecommunication networks</u></i></p>
<i>Network Utilities or Network Utility</i>	Support	The definition makes it clear what these terms mean, linking it to the definition of Network Utility Operator in the RMA	Retain the definition of <i>Network Utilities or Network Utility</i>
<i>Network Utility Operator or Network Utility Operation</i>	Support	The definition of <i>Network Utility Operator or Network Utility Operation</i> is supported as it is the RMA definition of Network Utility Operator.	Retain the definition of <i>Network Utility Operator or Network Utility Operation</i>
<i>Operational Need</i>	Support	The definition of <i>Operational Need</i> is supported as it is the National Planning Standards definition.	Retain the definition of <i>Operational Need</i>
<i>Pole</i>	Support in Part	As above, the definition of <i>Pole</i> is supported as it is the NESTF definition. This should be recognised	Amend the definition of <i>Pole</i> as follows: <u><i>has the same meaning as in clause 4 of the NES-TF (as set out in the box below)</i></u>

Section/Sub-section/Provision	Support/Support in Part/Oppose	Submission	Relief sought
		in the District Plan, as it is for the terms <i>Antenna</i> and <i>Cabinet</i>	<i>pole, mast, lattice tower, or similar structure, of a kind that is able to be used (with or without modification) to support antennas. [box to be inserted around NESTF words as per other definitions]</i>
<i>Radio Communication Facilities</i>	Support in Part	Radiocommunication can be utilised by Vodafone. The definition of radiocommunication facilities is supported, but should be supported by a definition of what Radiocommunication is. Radiocommunication is defined in the Radiocommunications Act 1989, and should be included in the District Plan.	Retain the definition of <i>Radio Communication Facilities</i> (noting that it should be <i>radiocommunication and not Radio Communication</i> in order to be consistent with the Radiocommunications Act 1989, and this needs to be consistent throughout the PDP). Add a new definition of <i>Radiocommunication</i> as follows: <i>has the same meaning as in the Radiocommunications Act 1989 (as set out in the box below) means any transmission or reception of signs, signals, writing, images, sounds, or intelligence of any nature by radio waves [box to be inserted around Radiocommunications Act 1989 words as per other definitions]</i>
<i>Reverse Sensitivity</i>	Support	<i>Reverse sensitivity</i> effects can occur on telecommunication companies, and an accurate definition of what those effects are is supported	Retain the definition of <i>Reverse Sensitivity</i>
<i>Service</i>	Amendment	The definition of <i>service</i> contains a list of services which are already defined as network utilities in the PDP. As such, the additional definition of <i>service</i> is unnecessary.	Delete the definition of <i>Service</i> in its entirety.
<i>Small Cell Unit</i>	Support	The definition of <i>Small Cell Unit</i> is supported as it is the NESTF definition.	Retain the definition of <i>Small Cell Unit</i>

Section/Sub-section/Provision	Support/Support in Part/Oppose	Submission	Relief sought
<i>Structure</i>	Support	The definition of <i>Structure</i> is supported as it is the RMA definition.	Retain the definition of <i>Structure</i>
<i>Telecommunication</i>	Support	The definition of <i>Telecommunication</i> is supported as it is the Telecommunication Act 2001 definition.	Retain the definition of <i>Telecommunication</i>
<i>Upgrading</i>	Amend	Add a definition of Upgrading	<p>Rule ECO-R3(1)(b)(vi) permits the <i>trimming or clearance of indigenous vegetation inside any area of significant indigenous vegetation and/or significant habitat of indigenous fauna (excluding natural wetlands)...that is...necessary to provide for the ongoing safe and efficient operation, maintenance and upgrading of telecommunication, radio communication and other network utilities, but excluding their expansion, where carried out by the respective network utility operator.</i></p> <p>In order to understand the limits of this rule, a definition of upgrading is needed. As such the following definition is proposed</p> <p><u>Upgrading means in relation to network utilities, means increasing the carrying capacity, efficiency, security, or safety of a network utility, where it does not result in a permanent change to the location of a structure.</u></p>
Abbreviations			
<i>NES-TF = Resource Management (National Environmental Standards for Telecommunication Facilities) Regulations 2016</i>	Support in Part	Typically, the Resource Management (National Environmental Standards for Telecommunication Facilities) Regulations 2016 are abbreviated as NESTF. For consistency with other	Amend the abbreviation for the Resource Management (National Environmental Standards for Telecommunication Facilities) Regulations 2016as follows:

Section/Sub-section/Provision	Support/Support in Part/Oppose	Submission	Relief sought
		District Plans, this is suggested for Central Hawkes Bay.	NES-TF NESTF = Resource Management (National Environmental Standards for Telecommunication Facilities) Regulations 2016 [subsequent changes will be necessary throughout the PDP for consistency]
National Direction Instruments			
<i>National Environmental Standards</i>	Support	The <i>National Environmental Standards</i> subsection of the <i>National Direction Instruments</i> section reinforces to plan users the discussion of National Environmental Standards under the <i>Statutory Context</i> subsection in the <i>How the Plan Works</i> .	Retain the National Direction Instruments section as notified
Part 2: District Wide Matters			
Strategic Direction			
New Strategic Direction for Infrastructure, with relevant Objectives.	Amendment	Within the strategic objectives there is no infrastructure recognition except for urban form and development. The majority of the Central Hawkes Bay District is Rural, which requires infrastructure as well as urban areas. A balance is needed, particularly given the critical nature of infrastructure for modern living, regardless of whether people are residing in urban or rural areas. Including Infrastructure as a Strategic Direction, with subsequent Strategic Objectives, provides a clear message to plan users as to the	Add a new strategic direction for <i>Infrastructure</i> , and include the following as Strategic Objectives under that heading: <u>1. The social, economic, environmental and cultural benefits of infrastructure are recognised and provided for, and its safe, efficient and effective development, upgrade, maintenance and operation is enabled;</u> <u>2. Infrastructure, including its role and function, is protected from incompatible development and activities; and</u> <u>3. The adverse effects of infrastructure on the surrounding environment are managed.</u>

Section/Sub-section/Provision	Support/Support in Part/Oppose	Submission	Relief sought
		strategic nature of infrastructure across the District as a whole.	<i><u>having regard to the economic benefits and the technical, functional and operational needs of infrastructure.</u></i>
Network Utilities			
<i>Initial Statement</i>	Support	The initial statement that <i>The provisions in this chapter override the respective Zone provisions in Part 3 Area-Specific Matters, unless otherwise specified in this chapter</i> provides clarity and supports the statements made in the Introduction and General Provisions section in Part 1 of the PDP	Retain the Initial Statement
<i>Introduction</i>	Support	The introduction is supported. It highlights the function of telecommunications and radiocommunications, highlights the need for customer connections, and reinforces the applicability of the NESTF (noting that the abbreviation in this introduction does not align with the abbreviations section of the PDP)	Retain the <i>Introduction</i> section, noting the need to ensure NESTF references align with NES-TF as per the abbreviation section of the PDP.
<i>Issues</i>	Support	The three issues raised in the Issues section provide context for the Objectives proposed in the PDP.	Retain the <i>Issues</i> section
<i>NU-01 Recognise and provide for safe, effective, efficient and resilient network utilities throughout the District that provide essential and secure services, including in</i>	Support in Part	NU-01 as proposed covers the same matters as best practice provision IE-01, although IE-01 provides greater context as to why network utilities	Delete <i>NU-01</i> in its entirety, and replace it with IE-01 from the best practice provisions attached in Appendix A.

Section/Sub-section/Provision	Support/Support in Part/Oppose	Submission	Relief sought
<i>emergencies, that enable people and communities to provide for their health, safety and wellbeing.</i>		should be safe, effective, efficient and resilient. See wording in body of submission to explain why best practice provisions should be utilised.	
<i>NU-O2 The adverse effects of network utilities on the environment are avoided, remedied or mitigated, while recognising the functional and operational needs of network utilities (including those associated with their scale, design and locational requirements).</i>	Support in Part	NU-O2 aligns with IE-O2 of the best practice provisions, although does not require consideration of the positive effects that network utilities can have. The definition of effect in the RMA includes positive effects.	Delete <i>NU-O2</i> in its entirety, and replace it with IE-O2 from the best practice provisions attached in Appendix A.
<i>NU-O3 The safety, maintenance, upgrade or development of network utilities is not compromised by incompatible subdivision, land use or development, including the potential for reverse sensitivity effects.</i>	Support in Part	The intention of NU-O3, in that it provides for Reverse Sensitivity is supported, but the objective should be made to be more explicit, as per Objective 3 (IE-O3) in the best practice provisions.	Delete <i>NU-O3</i> in its entirety, and replace it with IE-O3 from the best practice provisions attached in Appendix A.
<i>NU-P1 Recognise the national, regional and local importance and benefits of network utilities, including as lifeline utilities during an emergency...</i>	Support in Part	While the intention of NU-P1 is generally well aligned with IE-P1 of the best practice provisions, the second part of IE-P1 of the best practice provisions is more prescriptive than what exists in NU-P1 of the Proposed District Plan.	Delete <i>NU-P1</i> in its entirety, and replace it with IE-P1 from the best practice provisions attached in Appendix A.
<i>NU-P2 Avoid adverse effects of upgrades to, and the development of new, network utilities on the values and attributes of areas identified in the District Plan as</i>	Support in Part	The intention of NU-P2 is generally well aligned with IE-P5 (supported by IE-P7) of the best practice provisions.	Delete <i>NU-P2</i> in its entirety, and replace it with IE-P5 from the best practice provisions attached in Appendix A.

Section/Sub-section/Provision	Support/Support in Part/Oppose	Submission	Relief sought
<p>1. <i>Historical Heritage Items (in HH-SCHED2) and Notable Trees (in TREE-SCHED4);</i></p> <p>2. <i>Wāhi Tapu, Wāhi Taonga and Sites and Areas of Significance to Māori (in SASM-SCHED3);</i></p> <p>3. <i>Significant Natural Areas (in ECO-SCHED5); and</i></p> <p>4. <i>Outstanding Natural Features and Landscapes (in NFL-SCHED6);</i></p> <p><i>while recognising the extent to which adverse effects can be avoided, may be constrained by a network utility's functional or operational needs.</i></p>			
<p><i>IE-P3 Avoid significant adverse effects and remedy or mitigate other adverse effects of upgrades to, and the development of new, network utilities on the values and attributes of areas identified in the District Plan as:</i></p> <p>1. <i>High Natural Character Areas (in CE-SCHED7); and</i></p> <p>2. <i>Significant Amenity Features (in NFL-SCHED6);</i></p>	Support in Part	The intention of NU-P3 is generally well aligned with IE-P7 of the best practice provisions.	Delete <i>NU-P3</i> in its entirety, and replace it with IE-P7 from the best practice provisions attached in Appendix A.
<p><i>NU-P4 Manage the effects of network utilities on the environment by...</i></p>	Support in Part	The intention of NU-P4 is generally well aligned with IE-P4 of the best practice provisions. However for consistency IE-P4 of the best practice provisions should be used in the PDP.	Delete <i>NU-P4</i> in its entirety, and replace it with IE-P4 from the best practice provisions attached in Appendix A.

Section/Sub-section/Provision	Support/Support in Part/Oppose	Submission	Relief sought
<i>NU-P5 To protect network utilities from the adverse effects of subdivision, use and development that may constrain or compromise the safe, effective, secure and efficient operation, maintenance, upgrading and development of network utilities, and the safety and amenity values of people and the community, including by...</i>	Support in Part	The intention of NU-P5 is generally well aligned with IE-P8 of the best practice provisions. However for consistency IE-P8 of the best practice provisions should be used in the PDP.	Delete <i>NU-P5</i> in its entirety, and replace it with IE-P8 from the best practice provisions attached in Appendix A.
Proposed new policy – network utilities, land use, subdivision, development and growth	Amendment	While the proposed policies within the PDP (with proposed amendments) provide direction in terms of effects management in most day to day situations, ensuring co-ordination with the development of land where demand for telecommunications (and network utilities more generally) is helpful.	Add a new policy, being IE-P2 from the best practice provisions attached in Appendix A.
Proposed new policy – technological advances	Amendment	Telecommunications technology typically advances at a fast rate, evolving throughout the lifetime of a District Plan. Recognition that technologies can change is a useful provision for a District Plan to have.	Add a new policy, being IE-P3 from the best practice provisions attached in Appendix A.
Proposed new policy: Effects management in Natural Hazard Areas	Amendment	The proposed policies within the PDP do not provide guidance as to what Plan users must consider if telecommunications or any network utilities have a functional or operational need to be located in a hazard area. While some guidance is	Add a new policy, being IE-P6 from the best practice provisions attached in Appendix A.

Section/Sub-section/Provision	Support/Support in Part/Oppose	Submission	Relief sought
		provided in the Natural Hazards chapter, further guidance in the Network Utilities chapter is appropriate.	
<i>NU-R1 Operation, maintenance, replacement, and removal of existing network utilities (that are not regulated by an NES)</i>	Support	The rule is appropriate, including the matters of discretion should standards be exceeded.	Retain Rule <i>NU-R1</i>
<i>NU-R2 Minor upgrading of existing network utilities</i>	Support	It is appropriate to have provision for minor upgrading of network utilities. Some minor tweaks are sought to better align with permitted upgrading under the NESTF.	Amend NU-R2 as follows: <i>Where the following conditions are met:</i> <i>a. Limited to:</i> <i>i. The realignment, configuration, relocation or replacement of electricity, or telecommunication line pipe, pole, conductors, cross arms, switches, transformers, cabinets or ancillary structures must be:</i> <i>a. within 2m3m of the existing alignment or location; and</i> <i>b. within 5m of the existing alignment or location when associated with road widening, road safety or electricity clearance.</i> <i>ii. Alterations and additions to overhead electricity and telecommunication lines on existing poles must not:</i> <i>a. increase the number of conductors or wires/lines by more than 100 percent.</i> <i>b. exceed a diameter of 50mm; and</i> <i>c. have additional cross arms that exceed the length of the existing cross arm by more than 100 percent, up to a maximum of 4m.</i> <i>iii. The diameter of a replacement conductor or line must not exceed the diameter of the replaced conductor or line, or 50mm, whichever is the greater.</i>

Section/Sub-section/Provision	Support/Support in Part/Oppose	Submission	Relief sought
			<p><i>iv. The addition or replacement of earthwires (either overhead or underground) and underground earthgrids, may contain telecommunication lines and earthpeaks or above ground insulators on the poles.</i></p> <p><i>v. Any pole that replaces an existing pole must not:</i></p> <ul style="list-style-type: none"> <i>a. have a diameter or width that is twice that of the replaced pole at its widest point; or</i> <i>b. exceed three times the width of the replacement pole at its widest point, where a single pole is replaced with a pi pole; and</i> <i>c. have a height exceeding more than 1m above the height of the replaced pole or the relevant maximum height limit for above ground structures under NU-S3, whichever is the greater; and</i> <i>d. be replaced with a tower.</i> <p><i>vi. There must be no additional towers.</i></p> <p><i>vii. Any tower that replaces an existing tower must:</i></p> <ul style="list-style-type: none"> <i>a. not exceed the height of the replaced tower or the maximum height limit for above ground structures under NU-S3, whichever is the greater; and</i> <i>b. not have a footprint that exceeds the width of the existing tower by more than 25 percent.</i> <p><i>viii. Up to two additional electricity poles may be installed in existing networks where necessary to achieve conductor clearances required by NZCEP 34:2001.</i></p> <p><i>ix. The diameter of above ground replacement pipes must not exceed the diameter of the replaced pipe by more than 300mm.</i></p> <p><i>x. Where a new antenna replaces an existing antenna, the new antenna must not:</i></p>

Section/Sub-section/Provision	Support/Support in Part/Oppose	Submission	Relief sought
			<p>a. exceed <u>3.5m in length and 700mm in width</u> or the maximum dimension of the existing antenna by more than 20 percent, <u>whichever is the greater</u>; and</p> <p>b. where it is a dish antenna, <u>exceed 1.2m in diameter</u> or the diameter of the existing antenna by more than 20 percent, <u>whichever is the greater</u>; and</p> <p>c. where it is attached to a facility, increase the height of the facility <u>by more than 1m</u>, unless the height increase is a result of an increase in the size of the new antenna only.</p> <p>b. Compliance with:</p> <p>i. NU-S7 (Radio Frequency Fields); and</p> <p>ii. NU-S8 (Electric and Magnetic Fields).</p>
<p><i>NU-R3 Construction of new network utilities, and upgrading of existing network utilities (that are not regulated by an NES) – within the National Grid Yard (other than for the reticulation and storage of water for irrigation purposes carried out by a network utility operator)</i></p>	<p>Support</p>	<p>The rule is appropriate, including the matters of discretion should standards be exceeded.</p>	<p>Retain Rule <i>NU-R3</i></p>
<p><i>NU-R4 Construction of new network utilities, and upgrading of existing network utilities (that are not regulated by an NES), not already provided for in NU-R3 (within the National Grid Yard)</i></p>	<p>Support</p>	<p>The rule is appropriate, including the matters of discretion should standards be exceeded.</p>	<p>Retain Rule <i>NU-R4</i></p>
<p><i>NU-R8 Navigational aids, sensing and environmental monitoring equipment (including air quality and meteorological monitoring structures and devices)</i></p>	<p>Support</p>	<p>The rule is appropriate, including the matters of discretion should standards be exceeded.</p>	<p>Retain Rule <i>NU-R8</i></p>

Section/Sub-section/Provision	Support/Support in Part/Oppose	Submission	Relief sought						
<p><i>NU-S1 Gross Floor Area and Dimensions</i></p>	<p>Support in Part</p>	<p>NU-S1 provides clear dimension limits for telecommunications infrastructure, and aligns well with the NESTF. Some minor changes are sought to better provide for current telecommunications technologies and ensure alignment with the NESTF. Further a change to the title is suggested to widen the understanding as to what it is that the standard covers, as it is more than just GFA.</p>	<p>Amend NU-S1 as follows: <i>NU-S1 Gross Floor Area and Structure Dimensions</i></p> <table border="1" data-bbox="1413 357 2063 906"> <tr> <td data-bbox="1413 357 1738 488"> <p><i>General Residential Zone Settlement Zone Rural Lifestyle Zone Large Lot Residential Zone (Coastal)</i></p> </td> <td data-bbox="1738 357 2063 488"> <p>[Leave as is]</p> </td> </tr> <tr> <td data-bbox="1413 488 1738 695"> <p><i>Rural Production Zone General Rural Zone Rural Lifestyle Zone</i></p> </td> <td data-bbox="1738 488 2063 695"> <p>14. A telecommunications cabinet must not exceed a footprint of 2.5m² 5m² and height of 2m 2.5m. 15. A group of telecommunications cabinets must not exceed a combined footprint of 3m².</p> </td> </tr> <tr> <td data-bbox="1413 695 1738 906"> <p><i>Commercial Zone General Industrial Zone</i></p> </td> <td data-bbox="1738 695 2063 906"> <p>22. A telecommunications cabinet must not exceed a footprint of 2.5m² 5m² and height of 2m 2.5m. 23. A group of telecommunications cabinets must not exceed a combined footprint of 3m².</p> </td> </tr> </table>	<p><i>General Residential Zone Settlement Zone Rural Lifestyle Zone Large Lot Residential Zone (Coastal)</i></p>	<p>[Leave as is]</p>	<p><i>Rural Production Zone General Rural Zone Rural Lifestyle Zone</i></p>	<p>14. A telecommunications cabinet must not exceed a footprint of 2.5m² 5m² and height of 2m 2.5m. 15. A group of telecommunications cabinets must not exceed a combined footprint of 3m².</p>	<p><i>Commercial Zone General Industrial Zone</i></p>	<p>22. A telecommunications cabinet must not exceed a footprint of 2.5m² 5m² and height of 2m 2.5m. 23. A group of telecommunications cabinets must not exceed a combined footprint of 3m².</p>
<p><i>General Residential Zone Settlement Zone Rural Lifestyle Zone Large Lot Residential Zone (Coastal)</i></p>	<p>[Leave as is]</p>								
<p><i>Rural Production Zone General Rural Zone Rural Lifestyle Zone</i></p>	<p>14. A telecommunications cabinet must not exceed a footprint of 2.5m² 5m² and height of 2m 2.5m. 15. A group of telecommunications cabinets must not exceed a combined footprint of 3m².</p>								
<p><i>Commercial Zone General Industrial Zone</i></p>	<p>22. A telecommunications cabinet must not exceed a footprint of 2.5m² 5m² and height of 2m 2.5m. 23. A group of telecommunications cabinets must not exceed a combined footprint of 3m².</p>								
<p><i>NU-S2 Setbacks</i></p>	<p>Support in Part</p>	<p>A setback for structures is generally supported, in order to assist in the mitigation of bulk and dominance. However telecommunication pole facilities are typically slim, and do not create the bulk and dominance effect wider structures can have. As such, an exemption is sought for pole structures within the standard. It is noted there is no setback standard for structures in legal road, and a pole structure that is on a private site will give rise to similar negligible effects to a pole structure on legal</p>	<p>Amend NU-S2 as follows:</p> <table border="1" data-bbox="1413 938 2063 1358"> <tr> <td data-bbox="1413 938 1738 1358"> <p><i>General Residential Zone Settlement Zone Rural Lifestyle Zone Large Lot Residential Zone (Coastal)</i></p> </td> <td data-bbox="1738 938 2063 1358"> <p>1. Any part of an above ground building or structure (located outside road reserve) must be set back from the site boundary (excluding road boundaries) by a minimum distance of – 1.5m. <u>Except that:</u> <u>a. This standard does not apply to poles with a diameter of 600mm or less, and any permitted attachments to the poles.</u></p> </td> </tr> </table>	<p><i>General Residential Zone Settlement Zone Rural Lifestyle Zone Large Lot Residential Zone (Coastal)</i></p>	<p>1. Any part of an above ground building or structure (located outside road reserve) must be set back from the site boundary (excluding road boundaries) by a minimum distance of – 1.5m. <u>Except that:</u> <u>a. This standard does not apply to poles with a diameter of 600mm or less, and any permitted attachments to the poles.</u></p>				
<p><i>General Residential Zone Settlement Zone Rural Lifestyle Zone Large Lot Residential Zone (Coastal)</i></p>	<p>1. Any part of an above ground building or structure (located outside road reserve) must be set back from the site boundary (excluding road boundaries) by a minimum distance of – 1.5m. <u>Except that:</u> <u>a. This standard does not apply to poles with a diameter of 600mm or less, and any permitted attachments to the poles.</u></p>								

Section/Sub-section/Provision	Support/Support in Part/Oppose	Submission	Relief sought	
		road which has no setback requirement.		2. Any part of an above ground building or structure located within road reserve – No setback requirement.
			Rural Production Zone General Rural Zone	3. Any part of an above ground building or structure (located outside road reserve) must be set back from the site boundary (excluding road boundaries) by a minimum of – 5m. <u>Except that:</u> <u>a. This standard does not apply to poles with a diameter of 600mm or less, and any permitted attachments to the poles.</u>
			Commercial Zone General Industrial Zone	4. Any part of an above ground building or structure located within road reserve – No setback requirement. 5. No setback requirement.
<i>NU-S3 Height for Above Ground Buildings and Structures</i>	Support in part	The proposed heights for antennas attached to buildings should align with the NESTF (5m above the part of the building to which it is attached, and in Residential Zones only applies if the building is 15m or higher). The proposed height for antennas attached to poles should be increased so that they are at least 5m above the permitted building	Amend NU-S3 as follows: <i>Within road reserve or rail corridor – All Zones</i> 1. Above ground buildings adjoining the General Residential Zone, Settlement Zone, Rural Lifestyle Zone or Large Lot Residential Zone (Coastal) must not exceed a height of 2.3m. 2. Above ground buildings adjoining any other zone must not exceed a height of 3.5m. <i>Note: See standards below applying to above ground</i>	

Section/Sub-section/Provision	Support/Support in Part/Oppose	Submission	Relief sought
		<p>height in each zone (with the exception of the Rural zones). This assists in providing better coverage, as the antennas are above structures such as buildings which can interfere with their efficacy. In all Rural Zones (Rural Lifestyle, Rural Production, General Rural and Settlement), the pole height should be 25m to align with the NESTF. GPS antenna, which have a very small size, with effects akin to a lightning rod, should also be excluded from meeting the permitted height standard.</p> <p>It is unclear what the reference to Clause 4 is in standards 6, 7 and 8. The exception in ONF and ONL which has a smaller building height is not practicable for the addition of telecommunication facilities to existing structures/buildings. Removing the exception and making it easier for such facilities to be attached to existing buildings in these areas encourages consolidation of structures in areas where they are not readily expected.</p> <p>The height sought in industrial areas is considered appropriate as it encourages telecommunication companies who need new high facilities to be located in a zone where the amenity is lower, and power and fibre is typically available.</p>	<p><i>structures for the various zones (including where they are located within road reserve and the rail corridor)</i></p> <p><i>General Residential Zone Settlement Zone Rural Lifestyle Zone Large Lot Residential Zone (Coastal)</i></p> <p>3. Above ground buildings (where located outside road reserve and the rail corridor) must not exceed a height of 3.5m.</p> <p>4. Where an antenna is <u>can only be</u> attached to a building, the antenna and building must not exceed a combined height of 8.5m. <u>if that building is 15m high. The top of the antenna must not be more than 5m above the point of the building to which it is attached.</u></p> <p>5. Above ground structures (poles, towers, and telecommunication poles, including combined height of pole and antenna) must not exceed a height of 11.5m <u>13m</u>. Except that:</p> <p>a. Omni directional 'whip' or dipole antenna that complies with the dimensions in Standard NU-S1 are excluded from the 'combined height' (i.e. only the pole needs to comply with the maximum structure height standard).</p> <p>b. Lightning rods <u>and GPS antenna</u> are exempt from the</p>

Section/Sub-section/Provision	Support/Support in Part/Oppose	Submission	Relief sought	
			<p>Rural Production Zone <u>Settlement Zone</u> <u>Rural Lifestyle Zone</u> General Rural Zone</p>	<p>maximum structure height standard.</p> <p>6. Except as excluded in clause 4. below, above ground buildings (where located outside road reserve and the rail corridor) must not exceed a height of 5m. Except that: a. Where located within an Outstanding Natural Landscape or Outstanding Natural Feature identified in NFL-SCHED6, they must not exceed a height of 3m.</p> <p>7. Except as excluded in Clause 4 below, where an antenna is attached to a building, the top of the antenna and building must not exceed a combined height 8.5m must not be more than 5m above the point of the building to which it is attached. Except that: a. Where located within an Outstanding Natural Landscape or Outstanding Natural Feature identified in NFL-SCHED6, the antenna and building must not exceed a combined height of 6.5m.</p> <p>8. Except as excluded in clause 4. below, above ground structures (poles, towers and</p>

Section/Sub-section/Provision	Support/Support in Part/Oppose	Submission	Relief sought	
				<p><i>telecommunication poles, including combined height of pole and antenna) must not exceed a height of 25m.</i></p> <p><i>Except that:</i></p> <p><i>a. Omni directional 'whip' or dipole antenna that complies with the dimensions in Standard NU-S1 are excluded from the 'combined height' (i.e. only the pole needs to comply with the maximum structure height standard).</i></p> <p><i>b. Lightning rods and GPS antennas are exempt from the maximum structure height standard.</i></p> <p><i>9. Above ground buildings and structures in the Rural Production Zone must comply with Standard RPROZ-S13 Buildings and structures by Waipukurau Aerodrome.</i></p>
			<p><i>Commercial Zone General Industrial Zone</i></p>	<p><i>10. Above ground buildings (where located outside road reserve and the rail corridor) must not exceed a height of 5m.</i></p> <p><i>11. Where an antenna is attached to a building, the top of the antenna and building must not exceed a combined height 8.5m must not be more than 5m above the point of the building to which it is attached.</i></p>

Section/Sub-section/Provision	Support/Support in Part/Oppose	Submission	Relief sought
			<p>12. Above ground structures (poles, towers, and telecommunication poles, including combined height of pole and antenna) must not exceed a height of 15m25m.</p> <p>Except that:</p> <p>a. Omni directional 'whip' or dipole antenna that complies with the dimensions in Standard NU-S1 are excluded from the 'combined height' (i.e. only the pole needs to comply with the maximum structure height standard).</p> <p>b. Lightning rods and GPS antenna are exempt from the maximum structure height standard.</p>
<p><i>NU-S4 Height in Relation to Boundary</i></p>	<p>Support in Part</p>	<p>Like for NU-S2, a setback for structures, which is what a height in relation to boundary control essentially is, is generally supported as it assists in the mitigation of bulk and dominance effects. However telecommunication pole facilities are typically slim, and do not create the bulk and dominance effect wider structures can have. As such, an exemption is sought for pole structures within the standard.</p>	<p>Amend NU-S4 by adding the following exemption:</p> <p>1. Above ground buildings or structures (except those located within road reserve) must not exceed a height of 2m plus the shortest horizontal distance between that part of the building or structure and the nearest site boundary (but excluding a road boundary).</p> <p>Except that:</p> <p>a. Where the nearest site boundary immediately adjoins an access or part of an access held in the same ownership (wholly or partly) as the site on which the above ground building or structure is located, or it adjoins a registered right of way in favour of the site of the building or structure, the height in relation to boundary must be</p>

Section/Sub-section/Provision	Support/Support in Part/Oppose	Submission	Relief sought						
			<p><i>measured from the far side of the access or right of way.</i></p> <p><u>b. This standard does not apply to poles with a diameter of 600mm or less, and any permitted attachments to the poles.</u></p>						
<p><i>NU-S5 Access, Parking and Loading</i></p>	<p>Support in Part</p>	<p>Whilst it is appropriate that any new accesses comply with the relevant transport provisions of the PDP, having a threshold based on area should be replaced by whether or not the activity on the site demands a new access or not. Minimum parking or loading requirements are not necessary for telecommunications companies, as the operator will provide on site parking or loading to meet the demands of the activity.</p>	<p>Amend NU-S5 as follows:</p> <p>1. <u>Any activity which requires a new vehicle access</u><i>Activities on sites greater than 200m² in area must comply with the relevant vehicle access provisions of the TRAN – Transport chapter for access, parking and loading.</i></p>						
<p>Natural Hazards</p>									
<p><i>NH-APP1 – Building Importance Categories (BIC)</i></p>	<p>Support in Part</p>	<p>The approach to Natural Hazards is supported. For the avoidance of doubt, an amendment is sought to Building Importance Category 1 to ensure that network utility structures and activities which are not required as backup for Building Importance Category 4 are clearly provided for. Network utility structures and activities typically present a low degree of hazard to life and other property.</p> <p>A minor change to align with the definition of Pole in the PDP is also sought.</p>	<p>Amend NH-APP1 as follows:</p> <table border="1" data-bbox="1411 874 2060 1398"> <thead> <tr> <th data-bbox="1411 874 1626 959"><i>Building Importance Category (BIC)</i></th> <th data-bbox="1626 874 1845 959"><i>Description</i></th> <th data-bbox="1845 874 2060 959"><i>Examples</i></th> </tr> </thead> <tbody> <tr> <td data-bbox="1411 959 1626 1398"> <p>1</p> </td> <td data-bbox="1626 959 1845 1398"> <p><i>Structures presenting a low degree of hazard to life and other property</i></p> </td> <td data-bbox="1845 959 2060 1398"> <p>a. <i>Farm buildings, isolated structures and towers in the Rural Zones, not otherwise identified as BIC 2, 3 or 4.</i></p> <p>b. <i>Fences, poles masts, walls, in-ground swimming pools.</i></p> <p>c. <u>Network utility structures and activities</u></p> </td> </tr> </tbody> </table>	<i>Building Importance Category (BIC)</i>	<i>Description</i>	<i>Examples</i>	<p>1</p>	<p><i>Structures presenting a low degree of hazard to life and other property</i></p>	<p>a. <i>Farm buildings, isolated structures and towers in the Rural Zones, not otherwise identified as BIC 2, 3 or 4.</i></p> <p>b. <i>Fences, poles masts, walls, in-ground swimming pools.</i></p> <p>c. <u>Network utility structures and activities</u></p>
<i>Building Importance Category (BIC)</i>	<i>Description</i>	<i>Examples</i>							
<p>1</p>	<p><i>Structures presenting a low degree of hazard to life and other property</i></p>	<p>a. <i>Farm buildings, isolated structures and towers in the Rural Zones, not otherwise identified as BIC 2, 3 or 4.</i></p> <p>b. <i>Fences, poles masts, walls, in-ground swimming pools.</i></p> <p>c. <u>Network utility structures and activities</u></p>							

Section/Sub-section/Provision	Support/Support in Part/Oppose	Submission	Relief sought	
				<p><i>that are not classified as BICA</i> <i>d. Other structures with a gross floor area of 30m² or less.</i></p>
Historic Heritage				
<p><i>HH-R2 New underground electricity, gas or telecommunication customer connections, or the replacement of existing overhead electricity or telecommunication customer connections, affecting heritage items identified in HH-SCHED2</i></p>	<p>Support in Part</p>	<p>Provision to allow customer connections is supported. Included in this rule should be provision for the underground connection to attach, above ground, to the building in question, provided that the connection is not to the primary façade. Such examples include the provision of small boxes typically just above ground level on a building which provide access to the underground customer connection, facilitating the connection point between the network and the building (see Appendix B to this submission).</p>	<p>Amend HH-R2 as follows: 1. <i>Activity Status: PER</i> <i>Where the following conditions are met:</i> a. <i>No new support poles are required.</i> b. <i>The new or replaced connection work does not involve a change or addition to the exterior of the building, with the exception of small (less than 0.1m³ in volume) customer connection boxes which are not affixed to the primary façade of the building to which they are being attached.</i> <i>Note: Where this is not the case, the work will be assessed as an 'alteration'.</i></p>	
<p><i>HH-R6 External alterations to heritage items identified in HH-SCHED2</i></p>	<p>Support in Part</p>	<p>In order to provide clarity with the relief sought for HH-R2, an additional note under HH-R6 is sought so that any external alterations permitted under HH-R2 do not require consideration under HH-R6.</p>	<p>Amend HH-R6 as follows <i>HH-R6 External alterations to heritage items identified in HH-SCHED2</i> <i>Note: This rule does not apply to signs – signs are addressed in the SIGN – Signs chapter in the District Plan or any customer connections that result in external changes to the building that are permitted under Rule HH-R2.</i></p>	
Notable Trees				
<p><i>TREE-R2 The trimming of any notable tree identified in TREE-SCHED4 for network utilities</i></p>	<p>Support</p>	<p>The provisions within TREE-R2 are appropriate.</p>	<p>Retain <i>TREE-R2</i> as notified.</p>	

Section/Sub-section/Provision	Support/Support in Part/Oppose	Submission	Relief sought
Ecosystems and Indigenous Biodiversity			
<i>ECO-R3 Trimming or clearance of indigenous vegetation inside any area of significant indigenous vegetation and/or significant habitat of indigenous fauna (excluding natural wetlands)</i>	Support in Part	The rule is supported, but a definition of what upgrading includes is necessary to better understand the provision.	See definition section.
Natural Features and Landscapes			
Rules	Support	<p>The noted included under the Rules heading in this chapter that state:</p> <ul style="list-style-type: none"> • <i>Rules relating to earthworks in the identified ONL and ONFs are contained in the EW – Earthworks chapter of the District Plan;</i> and • <i>Rules relating to network utilities within the identified ONL and ONFs are contained in the NU – Network Utilities chapter of the District Plan. The rules in this chapter do not apply to network utilities</i> <p>are appropriate and should be retained.</p>	Retain Rules section, including notes, of NFL Section as notified.
Subdivision			
<i>SUB-O3 The provision of appropriate services to subdivided lots, in anticipation of the likely effects of land use activities on those lots, so as to ensure the health and safety of people and communities, and the maintenance or enhancement of amenity values.</i>	Support in Part	The objective is supported in that it requires services to allotments. This submission seeks that the term services as deleted from the definitions, as the term as notified solely relied on Council services, and not other infrastructure which is necessary to ensure the health and safety of people and communities, such as telecommunications. A consequential amendment is necessary to this objective.	Amend SUB-O3 as follows: <i>The provision of appropriate services network utilities to subdivided lots, in anticipation of the likely effects of land use activities on those lots, so as to ensure the health and safety of people and communities, and the maintenance or enhancement of amenity values.</i>

Section/Sub-section/Provision	Support/Support in Part/Oppose	Submission	Relief sought
<i>SUB-O4 Reverse sensitivity effects of subdivision on existing lawfully established activities (including network utilities) are avoided where practicable, or mitigated where avoidance is not practicable.</i>	Support	The objective is appropriate in that it seeks the protection of network utilities from reverse sensitivity effects that can arise from subdivision.	Retain <i>SUB-O4</i> as notified.
<i>SUB-P3 To allow the creation of lots of various sizes and dimensions for public works, network utility operations, renewable electricity generation, reserves and access.</i>	Support	The policy is appropriate in that it allows the subdivision of land for network utility purposes that does not have to meet the minimum lot size for the zone it is in.	Retain <i>SUB-P3</i> as notified.
<i>SUB-P6 To ensure upon subdivision or development, that all new lots or buildings are provided with a connection to a reticulated water supply, reticulated public sewerage system, and a reticulated stormwater system, where such adequate reticulated systems are available.</i>	Support in Part	The policy seeks that all new lots are appropriately connected to Council services. This should be widened to include other infrastructure which provides for the health and safety and economic and social wellbeing of the future lot occupants.	Amend <i>SUB-P6</i> as follows: <i>To ensure upon subdivision or development, that all new lots or buildings are provided with a connection to a reticulated water supply, reticulated public sewerage system, and a reticulated stormwater system, where such adequate reticulated systems are available, <u>and that all new lots or buildings are connected to a telecommunications network.</u></i>
<i>SUB-P12 To avoid or mitigate any adverse visual and physical effects of subdivision and development on the environment, including the appropriate underground reticulation of energy and telecommunication lines in order to protect the visual amenities of the area.</i>	Support in Part	This policy is appropriate in more visually sensitive areas, but it is inefficient in less visually sensitive areas. Acknowledgement of this should be made within the Policy.	Amend <i>SUB-P12</i> as follows: <i>To avoid or mitigate any adverse visual and physical effects of subdivision and development on the environment, including the appropriate underground reticulation of energy and telecommunication lines in order to protect the visual amenities of the area <u>Residential Zones and Commercial and Mixed Use Zones.</u></i>
<i>SUB-P17 To ensure, to the extent practicable, subdivision design that takes into account the location of regionally significant infrastructure, network utilities, renewable electricity generation sites and other lawfully established activities, and</i>	Support	This policy supports the direction set by SUB-O4.	Retain <i>SUB-P17</i> as notified.

Section/Sub-section/Provision	Support/Support in Part/Oppose	Submission	Relief sought				
<i>ensures that future land use activities will not result in reverse sensitivity effects.</i>							
New Standard	Amendment	A new standard is sought to ensure that, in all zones, telecommunications provision is provided at the time of subdivision.	<p>Add a new Standard as follows:</p> <table border="1"> <tr> <td colspan="2"><i><u>SUB-S10 Telecommunications</u></i></td> </tr> <tr> <td><i><u>All Zones</u></i></td> <td><i><u>All new lots must be able to connect to a telecommunications network.</u></i></td> </tr> </table> <p>This standard must be referenced in Rules SUB-R1, SUB-R3, SUB-R5, SUB-R7 and SUB-R7.</p>	<i><u>SUB-S10 Telecommunications</u></i>		<i><u>All Zones</u></i>	<i><u>All new lots must be able to connect to a telecommunications network.</u></i>
<i><u>SUB-S10 Telecommunications</u></i>							
<i><u>All Zones</u></i>	<i><u>All new lots must be able to connect to a telecommunications network.</u></i>						
<i>SUB-AM8 General</i>	Amendment	A new matter should be added to SUB-AM8 requiring applicants and decision makers to consider the effects resulting from the site not being connected to a telecommunications network.	<p>Amend <i>SUB-AM8</i> as follows:</p> <ol style="list-style-type: none"> <i>1. Any potential cumulative effects that may occur as a result of the subdivision.</i> <i>2. Potential constraints to the development of the site, such as the National Grid Subdivision Corridor or stormwater drains, and the ability for any resulting adverse effects to be avoided, remedied, or mitigated.</i> <i>3. The potential effects from a proposed subdivision or development of land on the safe and efficient operation of network utilities.</i> <i>4. The provision of electricity to the site boundary for any urban zone (GRZ – General Residential Zone, COMZ – Commercial Zone, GIZ – General Industrial Zone), to be confirmed by the electricity network utility as a condition of consent.</i> <i><u>5. The provision of telecommunications to each site.</u></i> 				
Earthworks							
<i>EW-R1 Specified Earthworks</i> <i>All Zones</i>	Support	The rule clearly permits earthworks associated with network utilities in all zones. This approach is supported.	Retain <i>EW-R1</i> as notified.				
Signs							

Section/Sub-section/Provision	Support/Support in Part/Oppose	Submission	Relief sought
<p><i>SIGN-R2 Official signs or signs for any public purpose or in connection with any public or network utility, community facility or public reserve</i></p> <p><i>All Zones</i></p>	<p>Support in Part</p>	<p>The rule clearly permits signs associated with network utilities in all zones, up to an area of 3m². Often, a telecommunications company will erect temporary signage advising of upgrade work to the network. This signage, and work, is often placed in legal road, which by definition is not a site. The rule should be amended to reflect this. The placement of a sign in legal road is approved by the road controlling authority via Corridor Access Requests. This process ensures such signs are placed in safe and appropriate locations.</p>	<p>Amend <i>SIGN-R2</i> as follows:</p> <p><i>1. Activity Status: PER</i></p> <p><i>Where the following conditions are met:</i></p> <p><i>a. Signs are located on the site to which they relate <u>(or, in the case of signs for network utilities, are placed within legal road)</u>.</i></p> <p><i>b. A sign must not exceed 3m² in area where it is visible from any public road, public land or adjacent property.</i></p> <p><i>c. Signs must not contain lights or illumination which flash, move, rotate, vary in intensity, colour or size.</i></p> <p><i>d. Signs must not visibly move, revolve, rotate, create an optical illusion of movement or change colour, whether by electrical or other means.</i></p>

Appendix A – Best Practice District Plan Provisions for Network Utilities

IE-O1 Network utilities

Effective, resilient, efficient and safe network utilities that:

1. provide essential and secure services, including in emergencies;
2. facilitate local, regional, national or international connectivity;
3. contribute to the economy and support a high standard of living;
4. integrate with urban development;
5. enable people and communities to provide for their health, safety and wellbeing.

IE-O2 Adverse effects of network utilities

The adverse effects of network utilities on the environment are avoided, remedied or mitigated while recognising:

1. the functional need and operational need of network utilities;
2. that positive effects of network utilities may be realised locally, regionally or nationally.

IE-O3 Adverse effects on network utilities

Network utilities are protected from adverse effects, including reverse sensitivity effects, of subdivision, use and development by, where necessary:

1. set-backs or buffer corridors within which incompatible activities will be managed;
2. controls on the activities of others' where they can compromise the operation, safety, maintenance, upgrade and development of network utilities.

Infrastructure and Energy Policies (Network Utilities)

IE-P1 Recognising the benefits of, and providing for, network utilities

1. Recognise the benefits of network utilities by:
 - a. enabling the operation, maintenance, repair, minor upgrade or removal of existing network utilities throughout the district;
 - b. enabling investigation, monitoring and navigation activities associated with network utility operations throughout the district;
 - c. providing for significant upgrades to, and the development of new, network utilities;
 - d. providing for the functions and responsibilities of network utilities as lifeline utilities during an emergency.

The national, regional and local benefits of network utilities that are recognised are those that enable the economic, social, cultural and environmental well-being of people and communities and provide for their health and safety, including through:

- a. the effective safe, secure and efficient transmission or distribution of electricity, gas, fuel or energy;
- b. an integrated, efficient and safe transport network for the movement of people and goods by land, air or water, including public transport, walking, cycling, private vehicles;
- c. effective, reliable and future-proofed communications networks and services;
- d. effective, resilient, efficient and safe water, wastewater and stormwater treatment systems, networks and services.

IE-P2 Network utilities, land use, subdivision, development and urban growth

Enable the coordination of network utilities planning and delivery with land use, subdivision, development and urban growth so that future land use and network utilities are integrated, efficient and aligned.

IE-P3 Technological advances

Provide flexibility for network utilities to adopt new technologies that:

1. improve access to, and efficient use of, networks and services;
2. allow for the re-use of redundant services and structures;
3. increase resilience, safety or reliability of networks and services;
4. result in environmental benefits and enhancements; or
5. promote environmentally sustainable outcomes including green infrastructure and the increased the utilisation of renewable resources.

IE-P4 Adverse effects of network utilities

Manage the adverse effects of network utilities on the environment by:

1. recognising that the adverse effects of the ongoing operation, maintenance, repair, upgrade and removal of existing network utilities are typically insignificant or minor by enabling these activities to occur without the need for planning approvals;
2. avoiding, remedying or mitigating the adverse effects of substantial upgrades to, or the development of new network utilities, including effects on:
 - a. natural and physical resources;
 - b. amenity values;
 - c. sensitive activities;
 - d. the safe and efficient operation of other network utilities;
 - e. the health, well-being and safety of people and communities.
3. managing the potential adverse effects of noise, vibration, radiofrequency fields and electric and magnetic fields by requiring compliance with national environmental standards or other nationally recognised standards or guidelines.
4. preferring the undergrounding of new network utilities in urban areas where it is:
 - a. technically feasible;
 - b. justified by the extent of adverse visual effects; and
 - c. viable, including where costs are proportionate to the adverse effects being avoided.

IE-P5 Adverse effects of network utilities on areas of outstanding or significant value

In the coastal environment

1. Avoid adverse effects of substantial upgrades to, or the development of new network utilities on:
 - a. the values and attributes of areas that are identified in the plan as having outstanding natural character, outstanding natural features or outstanding natural landscapes;
 - b. taxa, ecosystems or vegetation types identified as threatened, rare or protected in the plan in accordance with Policy 11(a) of the NZCPS;
2. avoid significant adverse effects of substantial upgrades to, or the development of new network utilities on the values and attributes of areas that are identified in the plan as having natural character, natural features, natural landscapes, or being significant

indigenous vegetation or significant habitats of indigenous fauna and remedy or mitigate other adverse effects.

In all areas

3. Give priority to avoiding the adverse effects of substantial upgrades to, or the development of new network utilities, on the values and attributes of areas that are identified in the plan as:
 - a. wetlands and lakes and rivers and their margins that have natural character;
 - b. outstanding natural features and landscapes outside of the coastal environment;
 - c. areas of significant indigenous vegetation and significant habitats of indigenous fauna outside of the coastal environment;
 - d. ancestral lands, water, sites, wāhi tapu and other taonga of mana whenua;
 - e. historic heritage.
4. Where the avoidance of adverse effects under clause (3) is not possible, the appropriateness of the substantial upgrades to, or the development of, new network utilities will be determined by having regard to the matters listed in {Link,5146,Policy IE-P7}.

IE-P6

Natural hazards and network utilities

Only provide for network utilities in areas identified in the plan as subject to natural hazards where the network utility:

1. does not pose a significant risk, or exacerbate an existing risk, to other people or property; and
2. has a functional need or operational need to be located in the area; or
3. is not vulnerable to the risks of the natural hazard; or
4. is designed to maintain reasonable and safe operation during and in the immediate aftermath of a natural hazard event.

IE-P7

Consideration of the adverse effects of network utilities

When considering the adverse effects of network utilities on the environment:

1. recognise that there may be situations where all adverse effects cannot be avoided, remedied or mitigated;
2. recognise that the adverse effects on the values and attributes of the areas listed in [Policy IE-P5\(3\)](#) can be mitigated by locating some types of network utilities in land transport corridors;
3. decision-makers must have regard to:
 - a. the extent to which adverse effects can be avoided, remedied or mitigated may be constrained by a network utility's functional need or operational need;
 - b. the time, duration or frequency of adverse effects;
 - c. the necessity of the network utility including:
 - i. the need to quickly repair and restore disrupted services;
 - ii. the impact of not operating, repairing, maintaining, upgrading, removing or developing a network utility;
 - d. existing network utilities including:
 - i. the complexity and connectedness of networks and services;
 - ii. the potential for co-location and shared use of network utility corridors;
 - e. anticipated outcomes for the receiving environment and the degree to which past modifications have compromised the achievement of those outcomes;

- f. the benefits derived from the network utility at a local, regional and national scale;
- g. the extent to which the network utility is integrated with, and necessary to support, planned urban development.

IE-P8 Adverse effects on network utilities

Protect network utilities from the adverse effects of subdivision, use and development that may constrain or compromise the safe and efficient operation, maintenance, repair, upgrading, removal and development of network utilities, including by:

1. locating and designing new buildings and activities sensitive to noise to avoid the potential adverse effects of the railway corridor and national and regional road network;
2. managing access to the railway corridor and national and regional road network;
3. managing new activities sensitive to noise within a defined air noise contour;
4. avoiding physical obstructions in take-off, approach, landing or departure paths and runway end protection areas;
5. requiring subdivision of sites containing significant electricity distribution lines to:
 - a. retain the ability for the network utility operator to access, operate, maintain, repair and upgrade the significant electricity distribution line; and
 - b. ensure that future buildings, earthworks and construction activities maintain safe electrical clearance distances under all building and electricity distribution line operating conditions;
6. managing land disturbance and activities sensitive to gas transmission to avoid or mitigate potential adverse effects of, and on, gas transmission pipelines;
7. requiring subdivision of sites containing a gas transmission pipeline to retain the ability for the network utility operator to access, operate, maintain, repair and upgrade the gas transmission pipeline;
8. managing the activities of others' through set-backs and design controls where it is necessary to achieve appropriate protection of a network utility.

Relevant Telecommunication Rules

IE-R1	Operation, maintenance, repair and removal of existing above and underground network utilities and ancillary vehicle access tracks	
all zones	Activity status: Permitted	Activity status when compliance not achieved:
	<p>Where this activity complies with the following rule requirements:</p> <ol style="list-style-type: none"> 1. IE-REQ1 Land disturbance. 2. IE-REQ5 Radio frequency fields. 3. IE-REQ6 Electric and magnetic fields. 	<ol style="list-style-type: none"> 1. Non-complying where compliance with IE-REQ5 Radio frequency field is not achieved. 2. Non-complying where compliance with IE-REQ6 Electric

[and magnetic fields](#)
is not achieved.

3. Discretionary where compliance with [IE-REQ1 Land disturbance](#) is not achieved.

IE-R2

New underground network utilities (including customer connections) and upgrading of existing underground network utilities

all zones

Activity status: Permitted

Activity status when compliance not achieved:

Where:

1. A new gas pipeline does not exceed a gauge pressure of 2,000 kilopascals.
2. In the root protection area of a tree that is identified by, and managed by, a rule in a District Plan, the network utility:
 - a. is at least 1 metre below ground level;
 - b. is installed by hand-digging or trenchless means (such as, air spade, hydro vac or directional drilling methods); and
 - c. has an entry point that either:
 - i. is located outside of the root protection area; or
 - ii. has an area of less than 1m².

1. Non-complying where compliance with [IE-REQ5 Radio frequency field](#) is not achieved.
2. Non-complying where compliance with [IE-REQ6 Electric and magnetic fields](#) is not achieved.
3. Non-complying where compliance with [IE-REQ4 National Grid](#) is not achieved.
4. Discretionary where compliance with [IE-REQ1 Land disturbance](#) is not achieved.
5. Restricted discretionary in all other circumstances.

Where this activity complies with the following rule requirements:

1. [IE-REQ1 Land disturbance](#).
2. [IE-REQ4 National Grid](#).
3. [IE-REQ5 Radio frequency fields](#).
4. [IE-REQ6 Electric and magnetic fields](#).

Matters of discretion are restricted to:

1. For a network utility within the root protection area of a tree:
 - a. methods proposed to reduce any adverse effects on the tree;

- b. the extent of the root protection area that is affected.
2. For a gas pipeline that has a gauge pressure greater than 2,000 kilopascals:
- a. the functional and operational needs of, and benefits derived from, the gas pipeline;
 - b. the risks of hazards affecting public or individual safety, and the risk of property damage;
 - c. measures to avoid or mitigate adverse effects, including separation from any activity sensitive to gas transmission;
 - d. technical advice, including an assessment of the level of risk;
 - e. when located within a land transport

corridor, the impacts on the operation, maintenance and upgrade of existing network utilities in that corridor.

IE-R3

Upgrading of existing above ground network utilities (excluding access track extensions)

all zones

Activity status: Permitted

Where:

1. The realignment, relocation or replacement of a telecommunication line, pipe (excluding a gas transmission pipeline), pole, tower, conductor, cross arm, switch, transformer or ancillary structure is within 5m of the existing alignment or location.
2. The realignment, relocation or replacement of a gas transmission pipeline is within:
 - a. an existing easement in favour of the pipeline; and
 - b. is within 12 metres of the existing alignment or location.
3. A pole is not replaced with a tower.
4. A replacement pole, tower or telecommunication pole does not exceed a height (network utility) whichever is the lesser of the following:
 - a. 25 metres; or
 - b. the height (network utility) of the replaced pole or tower or telecommunication pole by more than 30 percent.
5. The diameter or width of a replacement pole or telecommunication pole:
 - a. does not exceed twice that of the replaced pole at its widest point; or
 - b. where a single pole is replaced with a pi pole, the width of the pi pole structure must not exceed three times the width of the replaced pole at its widest point.
6. A replacement tower's footprint does not exceed the width of the tower by more than 25 percent.
7. A replacement pole or tower or telecommunication pole complies with height restrictions for any view shaft that is identified by, and managed by, a rule in a District Plan or does not increase the existing degree of non-compliance.

8. The diameter of a replacement conductor or line does not exceed the diameter of the replaced conductor or line or 50mm, whichever is the greater.
9. Additional conductors or lines:
 - a. do not increase the number of conductors or lines by more than 100 percent; and
 - b. have a diameter not exceeding 50mm.
10. There are no additional towers.
11. An additional pole, up to a maximum of two additional poles, is necessary to achieve the conductor clearances required by NZECP 34:2001.
12. Additional cross arms do not exceed the length of the existing cross arm by more than 100%, up to a maximum of 4 metres.
13. The diameter of replacement pipes does not exceed the diameter of the replaced pipe by more than 300mm.
14. The realignment, relocation or replacement of any other network utility structure or building:
 - a. must be within 5m of the alignment or location of the original structure or building;
 - b. must not increase the footprint of structure or building by greater than 30 percent.
15. In all zones including a protected area:
 - a. a replacement panel antenna does not increase the face area by more than 20 percent;
 - b. a replacement dish antenna does not increase in diameter by more than 20 percent.
16. In a historic heritage site that is identified by, and managed by, a rule in a District Plan:
 - a. a replacement antenna colour is the same or similar colour to a scheduled historic heritage building or structure.
 - b. a replacement panel antenna does not increase the face area by more than 20 percent;
 - c. a replacement dish antenna does not increase in diameter by more than 20 percent.

Where this activity complies with the following rule requirements:

1. [IE-REQ1 Land disturbance.](#)
2. [IE-REQ4 National Grid.](#)
3. [IE-REQ5 Radio frequency fields.](#)
4. [IE-REQ6 Electric and magnetic fields.](#)
5. [IE-REQ7 Aircraft protection.](#)

all zones

Activity status: Permitted

Activity status when compliance not achieved:
Discretionary

Where:

1. The new or extended vehicle access track is located outside of the following areas:
 - a. a protected area;
 - b. a historic heritage site that is identified by, and managed by, a rule in a District Plan;
 - c. a site of cultural value to tangata whenua that is identified by, and managed by, a rule in a District Plan.
2. The new or extended vehicle access track is in a visual amenity landscape (that is not for the protection of a viewshaft) has a maximum width of 3 metres excluding passing bays.

Where this activity complies with the following rule requirements:

Nil

IE-R6

Temporary network utilities

all zones

Activity status: P

Activity status when compliance not achieved:

Where:

1. The temporary network utility operates for a maximum of 12 months.
2. The temporary network utility is removed from the site when operation ceases.
3. The temporary network utility is setback at least 2 metres from a residential site boundary.

1. Non-complying where compliance with [IE-REQ5 Radio frequency fields](#) is not achieved.
2. Non-complying where compliance with [IE-REQ6 Electric and magnetic fields](#) is not achieved.
3. Non-complying where

Where this activity complies with the following rule requirements:

1. [IE-REQ1 Land disturbance](#).
2. [IE-REQ2 Noise](#).
3. [IE-REQ5 Radio frequency fields](#).
4. [IE-REQ6 Electric and magnetic fields](#).
5. [IE-REQ7 Aircraft protection](#).
6. [IE-REQ8 Outdoor lighting](#).

compliance with [IE-REQ7 Aircraft protection](#) is not achieved.

4. Restricted discretionary where compliance with [IE-REQ2 Noise](#) is not achieved.
5. Restricted discretionary where compliance with [IE-REQ8 Outdoor lighting](#) is not achieved.
6. Discretionary in all other cases.

Matters of discretion are restricted to:

1. The functional and operational needs of, and the benefits derived from, the network utility.
2. The purpose and necessity of the temporary network utility.
3. The potential adverse effects any noise generated by the temporary network utility having regard to the

level,
duration and
characteristics
of the noise
and the
nature and
proximity of
nearby
activities,
including the
amenity
values
associated
with the
receiving
environment.

4. The potential adverse effects of any outdoor lighting, particularly on the amenity values of the locality.
5. Any measures to avoid, remedy or mitigate adverse effects.
6. The potential to contribute to cumulative adverse effects on amenity values.
7. The potential adverse effects of any outdoor lighting on the values and attributes of a protected area, or a nationally

significant
dark sky area.

IE-R7 Electricity generators and self-contained power units for the supply of a network utility

**all
zones**

Activity status: Permitted

Activity status when compliance not achieved:

Where:

1. A electricity generator is back-up or emergency electricity supply purposes (and not the primary electricity supply) for a network utility.
2. A temporary electricity generator:
 - a. is transportable;
 - b. operates for a maximum of 12 months; and
 - c. is removed from the site when it ceases to be used.
3. A permanent back-up or emergency electricity generator or a self-contained power unit is not located in a:
 - a. protected area;
 - b. historic heritage site that is identified by, and managed by, a rule in a District Plan;
 - c. site of cultural value to tangata whenua that is identified by, and managed by, a rule in a District Plan;
 - d. visual amenity landscape.
4. A permanent back-up generator or a self-contained power unit is setback at least 2 metres from a residential site boundary.

1. Non-complying where compliance with [IE-REQ7 Aircraft protection](#) is not achieved.
2. Discretionary where compliance with [IE-REQ1 Land disturbance](#) is not achieved.
3. Restricted discretionary in all other cases.

Matters of discretion are restricted to:

1. The functional and operational needs of, and benefits derived from, the network utility.
2. The purpose and necessity of the generator or power unit.
3. The potential adverse effects of any noise generated, having regard to the level, duration and characteristics of the noise and the nature and proximity of nearby activities, including the amenity values associated with the receiving environment.
4. The potential adverse visual effects (including the effects of any outdoor lighting), particularly on the amenity values of the locality.
5. Any measures to avoid, remedy or mitigate adverse effects.
6. The potential to contribute to cumulative adverse effects on amenity values.
7. The potential adverse effects of on the values and attributes of:
 - a. a protected area;
 - b. a historic heritage site;
 - c. a site of cultural value to tangata whenua;
 - d. a visual amenity landscape;
 - e. a nationally significant dark sky area.

Where this activity complies with the following rule requirements:

1. [IE-REQ1 Land disturbance.](#)
2. [IE-REQ2 Noise.](#)
3. [IE-REQ7 Aircraft protection.](#)
4. [IE-REQ8 Outdoor lighting.](#)

IE-R8 New above ground customer connections

residential and commercial zones **Activity status:** Permitted

Where:

1. The connection does not include a new tower.
2. The connection does not exceed three additional poles.
3. The diameter of conductors, lines or cables does not exceed 30mm.
4. The connection is not to the primary feature of a heritage building or structure that is identified by, and managed by, a rule in a District Plan.

Where this activity complies with the following rule requirements:

1. [IE-REQ1 Land disturbance.](#)
2. [IE-REQ6 Electric and magnetic fields.](#)

Activity status when compliance not achieved:

1. Non-complying where compliance with [IE-REQ6 Electric and magnetic fields](#) is not achieved.
2. Controlled where compliance with Clause (4), relating to a heritage building or structure, is not achieved.
3. Discretionary in all other circumstances.

Matters over which control is reserved:

1. Effects on the values and characteristics of the heritage building or structure.
2. The extent to which any adverse effects on the values and characteristics of the heritage building or structure have been avoided or mitigated by the design, location and installation methods.

all other zones **Activity status:** Permitted

Where:

1. Outside of a land transport corridor, the connection does not exceed three additional poles up to a maximum of 25 metres in height (network utility) when located in a:
 - a. protected area;
 - b. historic heritage site that is identified by, and managed by, a rule in a District Plan;
 - c. site of cultural value to tangata whenua that is identified by, and managed by, a rule in a District Plan

- d. visual amenity landscape.
- 2. The diameter of conductors, lines or cables does not exceed 30mm.
- 3. The connection is not to the primary feature of a heritage building or structure that is identified by, and managed by, a rule in a District Plan.

Where this activity complies with the following rule requirements:

- 1. [IE-REQ1 Land disturbance.](#)
- 2. [IE-REQ6 Electric and magnetic fields.](#)

IE-R10	New network utilities in existing buildings	
all zones	<p>Activity status: Permitted</p> <p>Where:</p> <ul style="list-style-type: none"> 1. The new network utility does not modify the interior of a heritage building where the interior of the heritage building is specifically identified by, and managed by, a rule in a plan. <p>Where this activity complies with the following rule requirements:</p> <ul style="list-style-type: none"> 1. IE-REQ2 Noise. 2. IE-REQ6 Electric and magnetic fields. 	<p>Activity status when compliance not achieved:</p> <ul style="list-style-type: none"> 1. Non-complying where compliance with IE-REQ6 Electric and magnetic fields is not achieved. 2. Restricted discretionary for all other matters <p>Matters of discretion are restricted to:</p> <ul style="list-style-type: none"> 1. The functional and operational needs, and the benefits derived from, the network utility. 2. The purpose and necessity for the network utility.

3. Effects on the values and characteristics of the heritage building.
4. The potential adverse effects of any noise generated, having regard to the level, duration and characteristics of the noise and the nature and proximity of nearby activities, including the amenity values associated with the receiving environment.
5. Any measures to avoid, remedy or mitigate adverse effects.

IE-R12 New overhead lines and associated poles, telecommunication poles or towers

rural and industrial zones

Activity status: Permitted

Activity status when compliance not achieved:

Where:

1. Except when in a land transport corridor, a new overhead line is not located in a:
 - a. protected area;
 - b. historic heritage site that is identified by, and managed by, a rule in a plan;

1. Non-complying where compliance with [IE-REQ6 Electric and magnetic fields](#) is not achieved.
2. Non-complying where [IE-REQ7 Aircraft protection](#) is not achieved.
3. Non-complying when located outside of a land transport corridor and in a protected area in the coastal environment.

- c. site of cultural value to tangata whenua that is identified by, and managed by, a rule in a plan;
 - d. visual amenity landscape.
2. Poles or telecommunication poles do not exceed a height (network utility) of 25 metres.
 3. Towers do not exceed a height (network utility) of 15 metres.
 4. Discretionary in all other circumstances.

Where this activity complies with the following rule requirements:

1. [IE-REQ1 Land disturbance.](#)
2. [IE-REQ6 Electric and magnetic fields.](#)
3. [IE-REQ7 Aircraft protection.](#)

all other zones

Activity status: Discretionary

Activity status when compliance not achieved: Non-complying in all circumstances

Where:

1. The new overhead line is not in a protected area in the coastal environment.

Where this activity complies with the following rule requirements:

1. [IE-REQ6 Electric and magnetic fields.](#)
2. [IE-REQ7 Aircraft protection.](#)

IE-R13

New telecommunications kiosk

all zones

Activity status: Permitted

Activity status when compliance not achieved:

Where:

1. A telecommunication kiosk does not exceed:
 - a. a height of 3.5 metres;
 - b. an area of 1.5m².

1. Non-complying where compliance with [IE-REQ5 Radio frequency field](#) is not achieved.
2. Restricted discretionary in all other circumstances.
- 3.

Where this activity complies with the following rule requirements:

1. [IE-REQ5 Radio frequency fields.](#)

Matters of discretion are restricted to:

1. The potential adverse visual effects, particularly on the amenity values and streetscape of the locality.

IE-R15

New telecommunications poles and new antennas attached to poles (that are not regulated by the NESTF)

all zones in the land transport corridor

Activity status: Permitted

Activity status when compliance not achieved:

Where:

1. The combined height (network utility) of a telecommunications pole and antennas excludes omni-directional whip antennas does not exceed the permitted zone height limit established by a rule in a plan or the following, whichever is the greater:
 - a. 15 metres or zone height plus 5 metres whichever is the greater in a residential zone or local zone.
 - b. 20 metres or zone height plus 5 metres whichever is the greater in a neighbourhood commercial zone.
 - c. 25 metres in all other zones, or 30 metres where two or more users of the same pole.
2. A panel antenna:
 - a. does not exceed a width of 0.7 metres; and
 - b. when in a transport corridor or formed legal road, fits within an envelope of 3.5 metres in length and 0.7 metres in diameter.

1. Non-complying where compliance with [IE-REQ5 Radio frequency fields](#) is not achieved.
2. Non-complying where compliance with [IE-REQ7 Aircraft protection](#) is not achieved.
3. Discretionary where compliance with [IE-REQ1 Land disturbance](#) is not achieved.
4. Restricted discretionary in all other circumstances.
- 5.

Matters of discretion are restricted to:

1. The functional and operational needs of, an benefits derived from, the network utility.
2. The potential adverse visual effects, particularly on the

3. A dish antenna (that is not in the rail corridor) does not exceed a diameter of:
 - a. 0.38 metres when adjoining or in a:
 - i. Residential zone
 - ii. protected area;
 - iii. historic heritage site that is identified by, and managed by, a rule in a plan;
 - iv. site of cultural value to tangata whenua that is identified by, and managed by, a rule in a plan;
 - v. visual amenity landscape; or
 - b. 1.2 metres in adjoining or in open space, natural open space, sport and active recreation zones, rural or industrial zones or commercial excluding neighbourhood and local commercial zones outside the areas listed in 4(a).
 - c. 0.9 metres adjoining or in neighbourhood and local commercial zones locations outside the areas listed in 4(a).
 4. A dish antenna in a railway corridor does not exceed a diameter of:
 - a. 0.6 metres when in a:
 - i. protected area;
 - ii. historic heritage site that is identified by, and managed by, a rule in a District Plan;
 - iii. site of cultural value to tangata amenity values of the locality and streetscape.
3. The potential adverse effects on the values and attributes of:
 - a. a protected area;
 - b. an historic heritage site;
 - c. a site of cultural value;
 - d. a visual amenity landscape.
 4. The potential impacts on the operation, maintenance and upgrade of other network utilities.
 5. Any measures to avoid, remedy or mitigate adverse effects.
 6. The potential to contribution to cumulative effects on amenity values.

- whenua that is identified by, and managed by, a rule in a plan;
 - iv. visual amenity landscape; or
 - b. 1.2 metres outside the areas listed in 5(a).
- 5. Omni directional 'whip' or dipole antennas do not exceed:
 - a. 1.6 metres in vertical length;
 - b. Whip antenna or the cross section up to 60mm in diameter; and
 - c. 1.5 metres in horizontal length for a dipole antenna.
- 6. A headframe (excluding antenna and ancillary equipment) does not exceed the following:
 - a. 2.5 metres in diameter in residential zones (except when located on formed legal road as provided for by 3(b) above);
 - b. 6 metres in diameter in all other zones and unformed legal road.

Where this activity complies with the following rule requirements:

1. [IE-REQ1 Land disturbance.](#)
2. [IE-REQ5 Radio frequency fields.](#)
3. [IE-REQ7 Aircraft protection.](#)

all zones, outside of the transport corridor and outside of:

- a. a protected area;
- b. an historic heritage site that is identified by, and managed by a rule in a plan;
- c. a site of cultural value to tangata whenua that is identified by, and managed by, a rule in a plan;
- d. a visual amenity landscape.

Activity status: Permitted

Where:

1. The combined height (network utility) of a telecommunications pole and antennas excludes omni-directional whip antennas, do not exceed the permitted zone height limit established by a rule in a plan plus 5metres or the following, whichever is the greater:

Activity status when compliance not achieved:

1. Non-complying where compliance with [IE-REQ5 Radio frequency fields](#) is not achieved.
2. Non-complying where compliance with [IE-REQ7 Aircraft](#)

- a. 15 metres in a residential zone or local centre zone that adjoins a residential zone and is setback by 5 metres from a residential zone boundary (but not a road boundary)
 - b. 20 metres in a neighbourhood commercial zone, open space, natural open space, sport and active recreation zones, is a 5.0 metre setback from a residential zone boundary (but not a road boundary);
 - c. 35 metres when located in the rural and rural residential zones, or 40 metres where two or more users of the same pole;
 - d. 25 metres in all other locations, or 30 metres where two or more users of the same pole.
2. A panel antenna does not exceed a width of 0.7 metres.
 3. A dish antenna does not exceed a diameter of 0.6 metres in residential zones and 2.0 metres in all other zones.
 4. Omni directional 'whip' or dipole antennas do not exceed
 - a. 1.6 metres in vertical length;
 - b. 60mm in diameter; and
 - c. 1.5 metres in horizontal length.
 5. A headframe (excluding antennas and ancillary equipment) does not exceed the following:
 - a. 2.5 metres in diameter in residential zones
 - b. 6 metres in diameter in all other zones.
3. Discretionary where compliance with [IE-REQ1 Land disturbance](#) is not achieved.
 4. Restricted discretionary in all other circumstances.
 5. **Matters of discretion are restricted to:**
 1. The functional and operational needs of, an benefits derive from, the network utility.
 2. The potential adverse visual effects, potentially on the amenity values of the locality.
 3. Any measures to avoid, remedy or mitigate adverse effects.
 4. The potential contribution to cumulative effects on amenity values.

Where this activity complies with the following rule requirements:

1. [IE-REQ1 Land disturbance.](#)
2. [IE-REQ5 Radio frequency fields.](#)
3. [IE-REQ7 Aircraft protection.](#)

all zones, outside of the transport corridor and inside:

- a. a protected area;
- b. an historic heritage site that is identified by, and managed by a rule in a plan;
- c. a site of cultural value to tangata whenua that is identified by, and managed by, a rule in a plan;
- d. a visual amenity landscape.

Activity status: Permitted

Where:

1. Located in an outstanding natural landscape indentified in the Queenstown Lakes District Plan and:
 - a. the combined height (network utility) of a telecommunications pole and antenna does not exceed 8 metres;
 - b. the telecommunications pole and antenna is finished in colours with a light reflectance value of less than 16%.

Activity status when compliance not achieved:

1. Non-complying where compliance with [IE-REQ5 Radio frequency fields](#) is not achieved.
2. Non-complying where compliance with [IE-REQ7 Aircraft protection](#) is not achieved.
3. Non-complying when located in a protected area in the coastal environment.
4. Discretionary in all other circumstances.

Where this activity complies with the following rule requirements:

1. [IE-REQ1 Land disturbance.](#)
2. [IE-REQ5 Radio frequency fields.](#)
3. [IE-REQ7 Aircraft protection.](#)

IE-R16

New telecommunications poles and new antennas in road reserve (regulated by Regulations 26 or 28 of the NESTF that do not meet the permitted activity standards in Regulations 27 or 29 of the NESTF)

all zones

Activity status: Controlled

Where:

1. The permitted activity combined height (network utility), excluding ancillary equipment and whip antennas, of a telecommunications pole and antennas is exceeded by a maximum of 1.5 metre.
2. The telecommunications pole permitted activity notional envelope is exceeded by a maximum of 1.5 metre in height,

Activity status when compliance not achieved:

1. Non-complying where compliance with [IE-REQ5 Radio frequency fields](#) is not achieved.
2. Non-complying where compliance with [IE-REQ7 Aircraft protection](#) is not achieved.
3. Discretionary where compliance

excluding ancillary equipment and whip antennas, and a diameter of 0.8 metres.

3. A panel antenna does not exceed a width of 0.8 metres.
4. A dish antenna does not exceed a diameter of:
 - a. 0.6 metres in a residential zone;
 - b. 0.9 metres in all other zones.

with [IE-REQ1 Land disturbance](#) is not achieved.

4. Restricted discretionary in all other circumstances.

Matters of discretion are restricted to:

1. The functional and operational needs of, and benefits derived from, the network utility.
2. The potential adverse visual effects, particularly on the amenity values of the locality and streetscape.
3. Any measures to avoid, remedy or mitigate adverse effects.
4. The potential impacts on the operation, maintenance and upgrade of other network utilities.
5. The potential to contribute to cumulative effects on amenity values.

Matters over which control is reserved:

1. The extent to which a condition can address or mitigate the potential adverse visual effects, particularly on the visual amenity of the locality.
2. The potential impacts on the operation, maintenance and upgrade of other network utilities.

Where this activity complies with the following rule requirements:

1. [IE-REQ1 Land disturbance](#).
2. [IE-REQ5 Radio frequency fields](#).
3. [IE-REQ7 Aircraft protection](#).

Notification:

Application for resource consent under this rule will be decided without public notification.

IE-R17

New telecommunications poles and new antennas not in road reserve (including regulated by Regulations 30, 32 or 34 of the NESTF that do not meet the permitted activity standards in Regulations 31, 33 or 35 of the NESTF)

all zones outside

- a protected area;
- an historic heritage site that is identified by, and managed by, a rule in a plan;

Activity status: Controlled

Where:

1. The activity combined height (network utility) a telecommunications pole and

Activity status when compliance not achieved:

1. Non-complying where compliance with [IE-REQ5 Radio frequency fields](#) is not achieved.

- a site of cultural value to tangata whenua that is identified by, and managed by, a rule in a plan
- a visual amenity landscape.

antennas, excluding ancillary equipment and whip antennas

- In a rural and rural residential zones (not less than 50 metres from a residential zone or educational purpose building), the activity combined height (network utility) of a telecommunications pole and antennas, excluding ancillary equipment and whip antennas, does not exceed 40 metres, or 45 metres where two or more operators utilise the same pole.
 - In industrial zones, subject to being setback 5.0 metres from adjoining a residential zone, 30 metres or 35 metres where two or more operators utilise the same pole;
 - 25 metres, excluding residential in all other locations, or 30 metres where two or more users of the same pole.
- A panel antenna does not exceed a width of 0.8 metres (excluding than in a residential zone).
 - A dish antenna does not exceed a diameter of:
 - 0.6 metres in a residential zone;
 - 2.0 metres in all other zones.

Matters over which control is reserved:

- The extent to which a condition can address or mitigate the potential adverse visual effects, particularly on the visual amenity of the locality.

Where this activity complies with the following rule requirements:

- [IE-REQ1 Land disturbance.](#)
- [IE-REQ5 Radio frequency fields.](#)

- Non-complying where compliance with [IE-REQ7 Aircraft protection](#) is not achieved.
- Discretionary where compliance with [IE-REQ1 Land disturbance](#) is not achieved.
- Restricted discretionary in all other circumstances.
-
-

Matters of discretion are restricted to:

- The functional and operational needs of, and benefits derived from, the network utility.
- The potential adverse visual effects, particularly on the visual amenity of the locality.
- The potential adverse effects on the values and attributes of:
 - a protected area;
 - an historic heritage site;
 - a site of cultural value;
 - a visual amenity landscape.
- Any measures to avoid, remedy or mitigate adverse effects.

11. [IE-REQ7 Aircraft protection.](#)

5. The potential to contribute to cumulative effects on amenity values.

Notification:

Application for resource consent under this rule will be decided without public notification.

IE-R18

New antennas attached to a building (that are not regulated by the NESTF)

all zones

Activity status: Permitted

Activity status when compliance not achieved:

Where:

1. The face area of a panel antenna does not exceed 1.5m².
2. A dish antenna:
 - a. does not exceed a diameter of 1.2 metres; and
 - b. is not attached to building that is a historic heritage site identified by, and managed by, a rule in a District Plan;
3. The antenna does not exceed a height of 5 metres above the point of attachment to the building.
4. Is not attached to a building in a residential zone, except where the antenna is attached at least 15 metres above ground level.

1. Non-complying where compliance with [IE-REQ5 Radio frequency fields](#) is not achieved.
2. Restricted discretionary in all other circumstances.
- 3.

Matters of discretion are restricted to:

1. The functional and operational needs of, and benefits derived from, the network utility.
2. The potential adverse visual effects, particularly on the visual amenity of the locality.
3. Effects on the characteristics and values of a building that is a historic heritage site.
4. Measures to avoid, remedy or mitigate adverse effects.
5. The potential to contribute to cumulative effects

Where this activity complies with the following rule requirements:

1. [IE-REQ5 Radio frequency fields.](#)

on amenity values.

IE-R19

New antennas attached to a building (regulated by Regulation 36 of the NESTF that do not meet the permitted standards in Regulation 37)

all zones outside:

a. a protected area;

b. an historic heritage site that is identified by, and managed by, a rule in a plan;

c. a site of cultural value to tangata whenua that is identified by, and managed by, a rule in a plan;

d. a visual amenity landscape.

Activity status: Controlled

Where:

1. A new panel antenna does not exceed a maximum face area of 2m².

Matters over which control is reserved:

1. The extent to which a condition can address or mitigate the potential adverse visual effects, particularly on the visual amenity of the locality.
2. The top of the panel antenna is more than 5m above the part of the building at which the antennas is attached; or
3. If the building is in a residential zone, the lowest point at which the antenna is attached to the building is less than 15m above the ground.

Where this activity complies with the following rule requirements:

2. [IE-REQ5 Radio frequency fields](#).

Notification:

Application for resource consent under this rule will be decided without public notification.

Activity status when compliance not achieved:

1. Non-complying where compliance with [IE-REQ5 Radio frequency fields](#) is not achieved.
2. Restricted discretionary in all other circumstances.
- 3.

Matters of discretion are restricted to:

1. The functional and operational needs of, and benefits derived from, the network utility.
2. The potential adverse visual effects, particularly on the visual amenity of the locality.
3. Measures to avoid, remedy or mitigate adverse effects.
4. The potential to contribute to cumulative effects on

amenity values.

all zones in:

a. a protected area;

b. an historic heritage site that is identified by, and managed by, a rule in a plan;

c. a site of cultural value to tangata whenua that is identified by, and managed by, a rule in a plan;

d. a visual amenity landscape.

Activity status: Restricted discretionary

Where:

Nil

Activity status when compliance not achieved:

Non-complying

Matters of discretion are restricted to:

1. The functional and operational needs of, and benefits derived from, the network utility.
2. The potential adverse visual effects, particularly on the visual amenity of the locality.
3. The potential adverse effects on the values and attributes of:
 - a. a protected area;
 - b. an historic heritage site or building;
 - c. a site of cultural value to tangata whenua;
 - d. a visual amenity landscape.
4. measures to avoid, remedy or mitigate adverse effects.
5. The potential to contribute to cumulative adverse effects.

Where this activity complies with the following rule requirements:

1. [IE-REQ5 Radio frequency fields.](#)

Notification:

Application for resource consent under this rule will be decided without public notification.

IE-R20

New telecommunications cabinets (regulated by Regulation 19 of the NESTF that do not meet the permitted standards in Regulation 20, 21 and 22)

all zones outside of:

a. a protected area;

b. an historic heritage site that is identified by, and managed by, a rule in a plan;

Activity status: Controlled

Where:

1. A single telecommunications cabinet does not have a footprint

Activity status when compliance not achieved:

1. Restricted discretionary in all other circumstances.

- c. a site of cultural value to tangata whenua that is identified by, and protected by, a rule in a plan;
- d. a visual amenity landscape.

exceeding 2.5m² or a height (network utility) of 2 metres.

- 2. A group of telecommunications cabinets does not have a footprint exceeding 3m².

2.

Matters of discretion are restricted to:

- 1. The functional and operational needs of, and the benefits derived from, the network utility.
- 2. The potential adverse visual effects, particularly on the visual amenity of the locality and streetscape.
- 3. The potential effects on the operation, maintenance and upgrade of other network utilities.
- 4. Measures to avoid, remedy or mitigate adverse effects.
- 5. The potential to contribute to cumulative effects on amenity values.

Matters over which control is reserved:

- 1. The potential adverse visual effects, particularly on the visual amenity of the locality and streetscape.
- 2. The potential effects on the operation, maintenance and upgrade of other network utilities.

Where this activity complies with the following rule requirements:

Nil

Notification:

Application for resource consent under this rule will be decided without public notification.

all zones in:

- a. a protected area;
- b. an historic heritage site that is identified by, and managed by, a rule in a plan;
- c. a site of cultural value to tangata whenua that is identified by, and protected by, a rule in a plan;
- d. a visual amenity landscape.

Activity status: Controlled

Where:

- 1. Located in a land transport corridor and
 - a. A single telecommunications cabinet does not have a footprint exceeding 2.5m² or a height (network utility) of 2 metres; and

Activity status when compliance not achieved:

- 1. Non-complying where compliance with [IE-REQ5 Radio frequency](#)

- b. A group of telecommunications cabinets does not have a footprint exceeding 3m².

[fields](#) is not achieved.

- 2. Discretionary in all other circumstances.

Matters over which control is reserved:

- 1. The potential adverse visual effect, particularly on the visual amenity of the locality and streetscape.
- 2. The potential effects on the operation, maintenance and upgrade of existing network utilities.
- 3. The potential adverse effects on the values and attributes of:
 - a. a protected area;
 - b. an historic heritage site;
 - c. a site of cultural value to tangata whenua;
 - d. a visual amenity landscape.

3.

Where this activity complies with the following rule requirements:

- 1. [IE-REQ5 Radio frequency fields](#).

Notification:

Application for resource consent under this rule will be decided without public notification.

E-R30	New minor utility structures, including cabinets (that are not regulated by the NESTF)	
<p>all zones in a land transport corridor; and</p> <p>all zones outside of a land transport corridor not in:</p> <ul style="list-style-type: none"> a. a protected area; b. an historic heritage site that is identified by, and 	<p>Activity status: Permitted</p> <p>Where:</p> <ul style="list-style-type: none"> 1. A new minor utility structure does not exceed: <ul style="list-style-type: none"> a. a maximum floor area of 6m². b. a maximum height 	<p>Activity status when compliance not achieved:</p> <ul style="list-style-type: none"> 1. Discretionary when compliance with IE-REQ1 Land disturbance is not achieved. 2. Restricted discretionary in all other circumstances. <p>Matters of discretion are restricted to:</p> <ul style="list-style-type: none"> 1. The functional and operational needs of, and benefits derived from, the minor utility structure.

managed by, a rule in a plan;
 c. a site of cultural value to tangata whenua that is identified by, and managed by, a rule in a plan;
 d. a visual amenity landscape.

(network utility) of 1.8 metres.

Where this activity complies with the following rule requirements:

1. [IE-REQ1 Land disturbance.](#)
2. [IE-REQ2 Noise.](#)

2. The purpose and necessity of the minor utility structure.
3. The potential visual effects, particularly on the visual amenity of the locality and streetscape.
4. The potential effects on the operation, maintenance and upgrade of existing network utilities.
5. The potential adverse effects of any noise generated, having regard to the level, duration and characteristics of the noise and the nature and proximity of nearby activities, including the amenity values associated with the receiving environment.
6. The potential adverse effects on the values and attributes of:
 - a. a protected area;
 - b. an historic heritage site;
 - c. a site of cultural value to tangata whenua;
 - d. a visual amenity landscape.
7. Any measures to avoid, remedy or mitigate adverse effects.
8. The potential to contribute to cumulative adverse effects.

all zones outside of a land transport corridor and in:

a. a protected area;

Where:
Nil

b. an historic heritage site that is identified by, and managed by, a rule

Where this activity complies with the following rule requirements:

in a plan;

c. a site of cultural value to tangata whenau that is identified by, and managed by, a rule in a plan;

d. a visual amenity landscape.

IE-R31

New network utilities (including network utility buildings and enclosed substations) not provided for by another Rule

in all zones outside of:
 a. a protected area;
 b. an historic heritage site that is identified by, and managed by, a rule in a plan;
 c. a site of cultural value to tangata whenua that is identified by, and managed by, a rule in a plan;
 d. a visual amenity landscape.

Activity status: Permitted

Where:

1. A building does not exceed a height of 10 metres or the permitted zone height limit established by a rule in a plan, whichever is the greater.
2. A building does not exceed an area of 20m².
3. A building is setback 2 metres from a residential boundary.
4. A building is setback 5 metres from a railway corridor boundary.

Where this activity complies with the following rule requirements:

1. {IE-REQ1 Land disturbance}.
2. {IE-REQ2 Noise}.
3. {IE-REQ3 Parking and access}.
4. {IE-REQ4 National Grid}.
5. {IE-REQ5 Radio frequency fields}.
6. {IE-REQ6 Electric and magnetic fields}.
7. {IE-REQ7 Aircraft protection}.
8. {IE-REQ8 Outdoor lighting}.

Activity status when compliance not achieved:

1. Non-complying when compliance with {IE-REQ4 National Grid} is not achieved.
2. Non-complying when compliance with {IE-REQ5 Radio frequency fields} is not achieved.
3. Non-complying when compliance with [IE-REQ6](#) Electric and magnetic fields} is not achieved.
4. Non-complying when compliance with {IE-REQ7 Aircraft protection} is not achieved.
5. Restricted discretionary when compliance with {IE-REQ2 Noise} is not achieved.
6. Restricted discretionary when compliance with {IE-REQ3 Parking and

access} is not achieved.

7. Restricted discretionary when compliance with {IE-REQ8 Outdoor lighting} is not achieved.
8. Discretionary in all other circumstances.

Matters of discretion are restricted to:

1. The functional and operational needs of, and benefits derived from, the network utility.
2. The purpose and necessity of the network utility.
3. The potential adverse effects of any noise generated, having regard to the level, duration and characteristics of the noise and the nature and proximity of nearby activities, including the amenity values associated with the

receiving environment.

4. The potential effects of outdoor lighting, particularly on the amenity values associated with the locality.
5. Impacts on the safe and efficient operation of the transport network.
6. Any measures to avoid, remedy or mitigate adverse effects.
7. The potential to contribution to cumulative effects on amenity values.

in all zones in:

- a. a protected area;
- b. an historic heritage site that is identified by, and managed by, a rule in a plan;
- c. a site of cultural value to tangata whenua that is identified by, and managed by, a rule in a plan;
- d. a visual amenity landscape.

Activity status: Discretionary

Where:

1. A new network utility is not located in a protected area in the coastal environment.

Where this activity complies with the following rule requirements:

1. {IE-REQ4 National Grid}.
2. {IE-REQ5 Radio frequency fields}.
3. {IE-REQ6 Electric and magnetic fields}.

Activity status when compliance not achieved:

Non-complying

4. {IE-REQ7 Aircraft protection}.

Appendix B – Example of Customer Connection Boxes Attached to Buildings



Figure 1 – BUDI Customer Connection Box

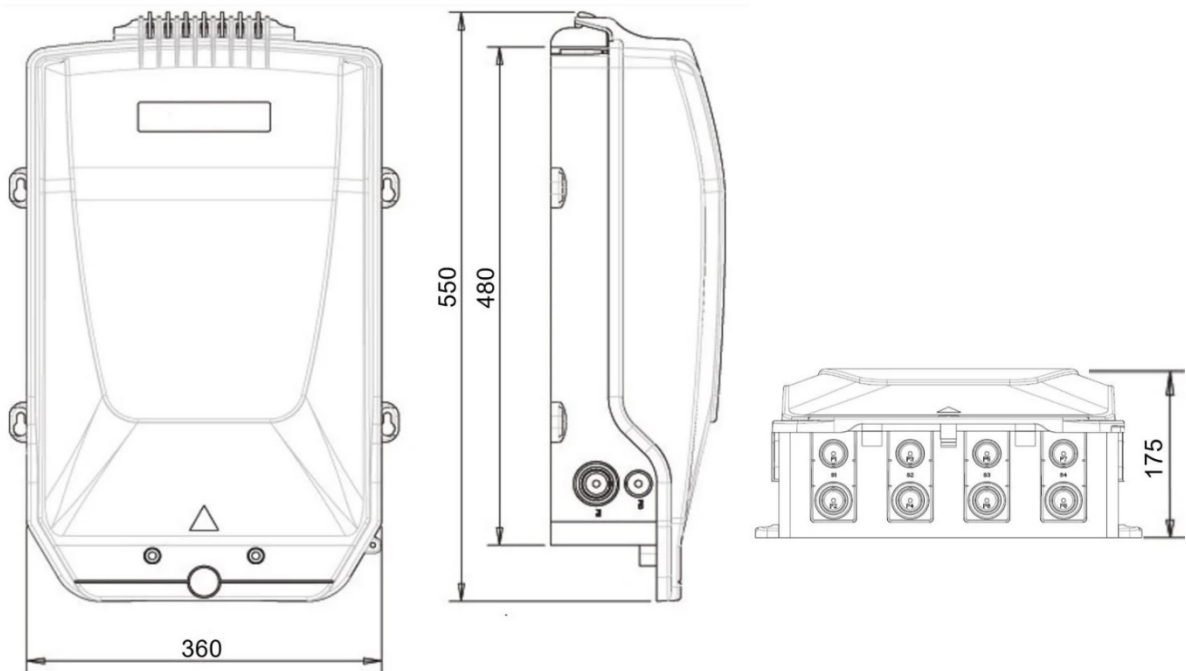

Figure 3 – BUDI Customer Connection Box Dimensions (in mm)